

.MANUFACTURE XXI

**Limited editions  
from an experimental  
design.**

2024 Edition

# Luo Collection



## Material(s)

---

Luo is a collection of pieces made from cold hollow castings covered with reinforced mortar, an under-exploited material. This material allows us to create modules for interior and exterior use, without any plastic or internal.

## Shape(s)

---

Luo explores many combinations. Each module presents a downstroke and a ligature. These elements make it possible to create natural junction points that allow for many configurations.





Coffee table  
2 sections

LUO01

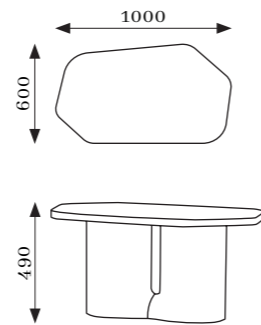

26.7kg

Customizable  
size and colors







Coffee table  
3 sections  
LUO02

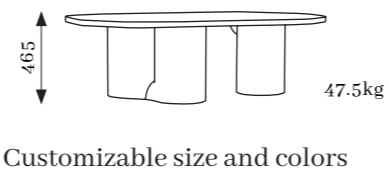
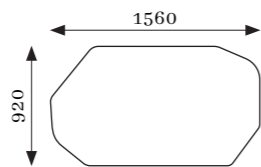





Luo Console  
LUO03

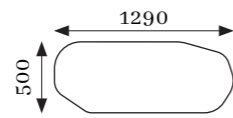

Customizable size and colors



48kg







# Oval Luo Table 4 legs

LU004

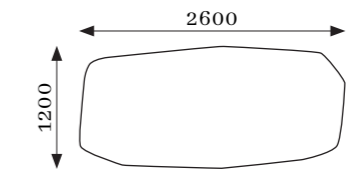
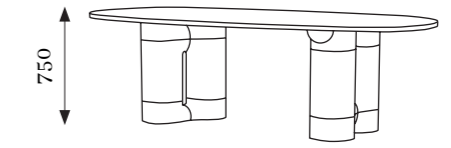

110kg

Customizable size and colors



# Ovoid Luo Table

LU005

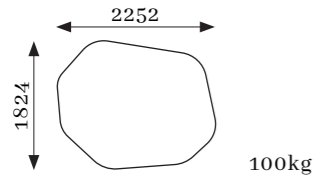
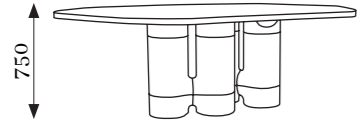

Customizable size and colors







# Luo Table 3 vanished legs

LU006

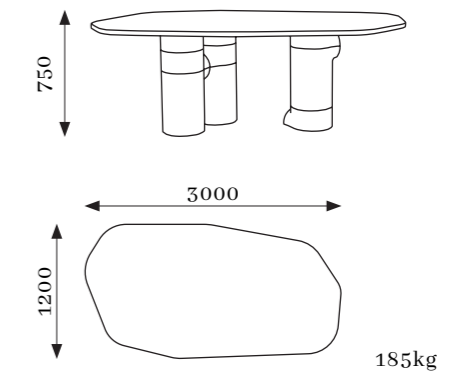

Customizable size and colors



# Lithos Collection



## Material(s)

Lithos explores a versatile fabrication technique based on a structure made of industrial cardboard and then coated with mortar. The collection is the focus of research into the finishing techniques of the coating applied to the piece of furniture. The mortar can be coloured in the mass with pigments. A protective varnish means that other colouring methods can also be considered. Each piece reveals a gradation which, applied progressively in the varnish, enhances the curvature of the structure.

## Shape(s)

Each Lithos structure is constituted in a random and instinctive way to create sinuous and coloured objects, declinable in multiple formats. It is entirely possible to create these shapes without recourse to moulds, thereby generating new effects. Alone or grouped together, the modules can be used to display objects, as a coffee table, a sideboard, as a table, or as a free form that will live by its presence alone.





# Lithos Bench

LITHOS01

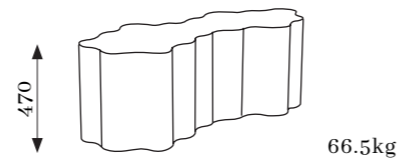
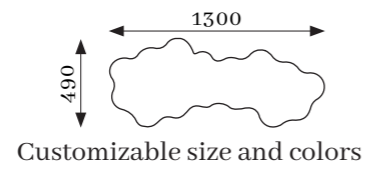





Lithos Console  
LITHOS02

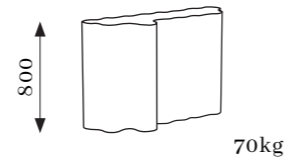
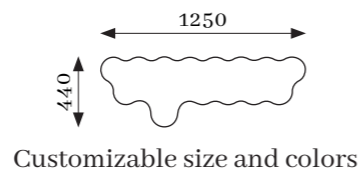





# Large Lithos Table

LITHOS03

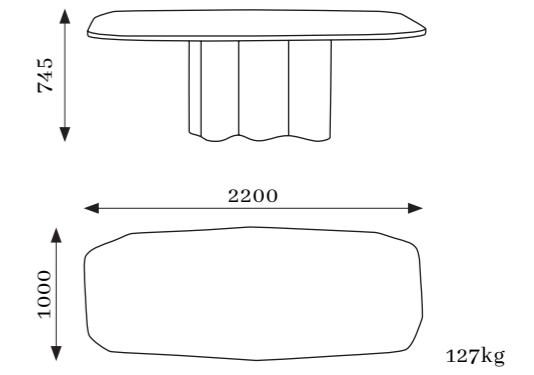

Customizable size and colors









# Noda Collection

## Material(s)

---

Lamps are made from an eco-responsible composite, formulated with recycled-cellulose. Cold transformed, this solution can be molded or shaped. Mass-dyed with natural pigments, the collection is made up of 3 shades, however the color possibilities are endless. Textured, smooth, matte or glossy finishes are possible.

## Shape(s)

---

From the research of our experimental studio within our Cogitech parent company, Noda lamps are inspired by the plant world by displaying an organic design reminding of a tree branch birth.

The plant world fascinates with its uniqueness and its ability to adapt to resources. In seeking the light, the branches of the trees draw technical elements such as a knot, a branch or even a bud. It is through ramification that the tree adapts to its environment and evolves towards ever more "living". The branch represents life at its freshest state. Its colorful trunk forms a branch which seeks light at its end. Noda lamps embody the force of nature, authenticity through material chosen, and softness through rounded shapes.

Each piece is unique, with variations in appearance that reinforce its authentic character.





Noda II  
NODA02

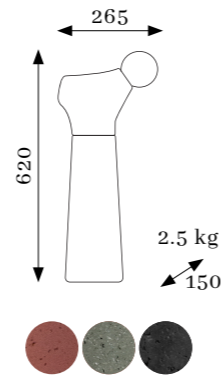



# Noda III

NODA03

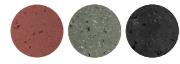
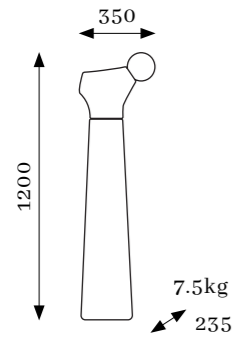

Diam 120mm  
E27 - 640Lm









**MADE IN FRANCE**  
**MADE IN BURGUNDY**  
**CUSTOM-MADE**





## .MANUFACTURE XXI

16 rue Marcel Sembat, 21000 Dijon  
+33 (0)3 45 58 01 46 - manufacture21.fr  
contact@manufacture21.fr

